



Water Jet Loom

LWT810

**Innovation for the Future. Reliability From the Past.
The New Toyota LWT 810 Water Jet Loom For TODAY.**

The LWT810 enhances the productivity and the quality with the latest technology advancements that customers expect from Toyota while achieving the highest energy savings to protect our environment.



**High
Quality
&
Improved
Productivity**

Offering a short stroke and extending weft insertion time has allowed drastic improvements to high-speed operation and enhanced quality while placing minimum strain on the yarn.

**Operability
&
Support**

The new function panel offers the latest in electronic technology advancements and troubleshooting including enhanced visibility, improved machine operation functionality, and handling.

**Factory
Management**

New factory management system, based on the Toyota Monitoring System (TMS), offers an increased management level of productivity and quality in real-time by displaying shift reports, actual factory floor layout, and operation status in various formats.

New Water Jet Loom – Lives Up to Customer Expectations.

High Quality & Improved Productivity

■ New Beating Motion

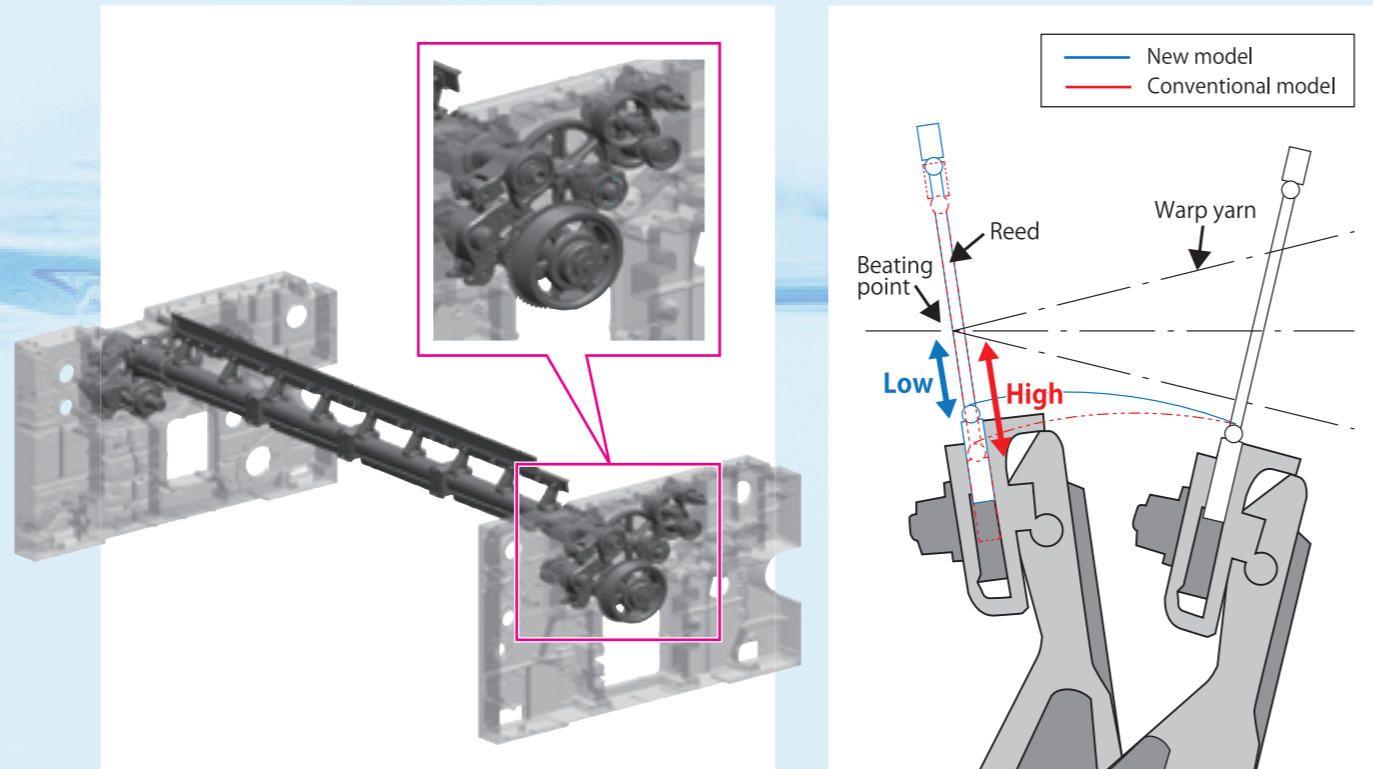

The newly designed Beating Motion provides a 50% reduction of machine vibration through the use of lighter weight materials, hardened beating related components, and applying balance weights across the full width of the machine.

Enhanced beating motion can achieve higher versatility weaving for high-quality textiles.

■ Micronozzle & ML-Beating

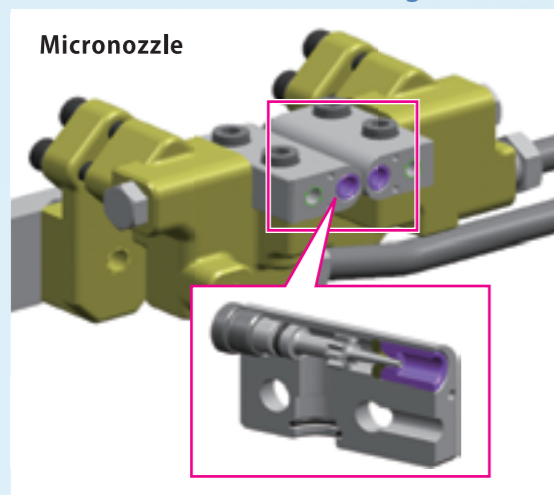

*One color is an option

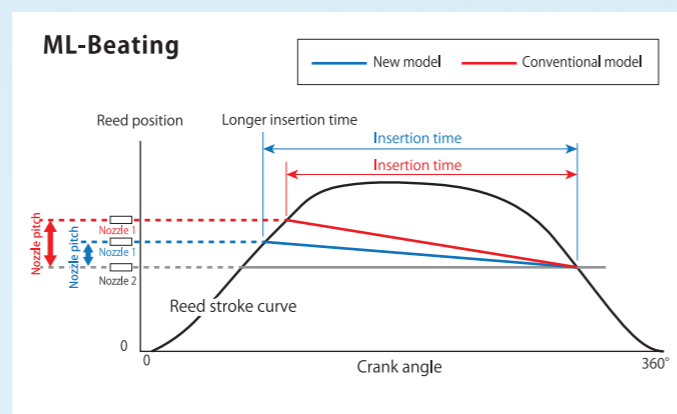

Our newly improved ML Beating curve allows an increased weft insertion time for reliable operation. In addition, the combination of a micro nozzle can provide a higher level of operation.

Operability & Support

■ New Function Panel



The large 12-inch panel provides simple and easy operability with a strong graphical presentation.

■ New Weave Assist System (WAS)

In addition to the existing functions (ICS settings, electrical & mechanical parameters) that enable optimum weaving conditions to be set automatically by selecting the fabric parameters, a newly designed Adjustment Support function was developed. This system assists the operator in making adjustments to reduce stop marks and the number of faults. In addition, for quality control purposes, WAS monitors the number of faults and abnormalities. If problems arise, the system warns and stops the machine to prevent defects. Total management is also available in conjunction with FACT.



Factory Management

■ FACT (Toyota Factory Management System) **OP**

FACT is a new factory management system derived from TMS, which was well received with the LWT710.

*Please refer to page 9 for details.

■ Internet TTCS **OP**

Operators can instantly check the production status of their mill from anywhere in the world via the Internet. This advanced system enables total production management including monitoring machines, obtaining maintenance records, and keeping track of the entire weaving process.

Technology – Weave Wide Range of Fabrics.



■ Roller Feeder with Speed Control

Smooth yarn separation by rollers prevents yarn latching and assures stable weft measuring. It has excellence functions for weaving mono-filament high-twisted yarns such as loose-winding and pull-back.

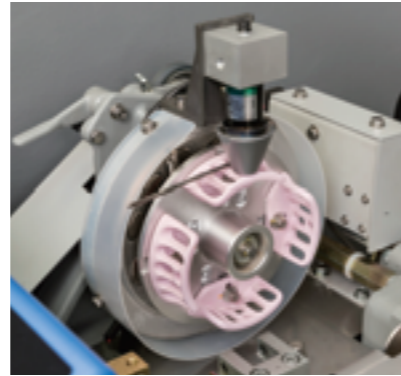

■ BLD Measuring Device

The weft tension can be lowered and damage of weft is minimized.

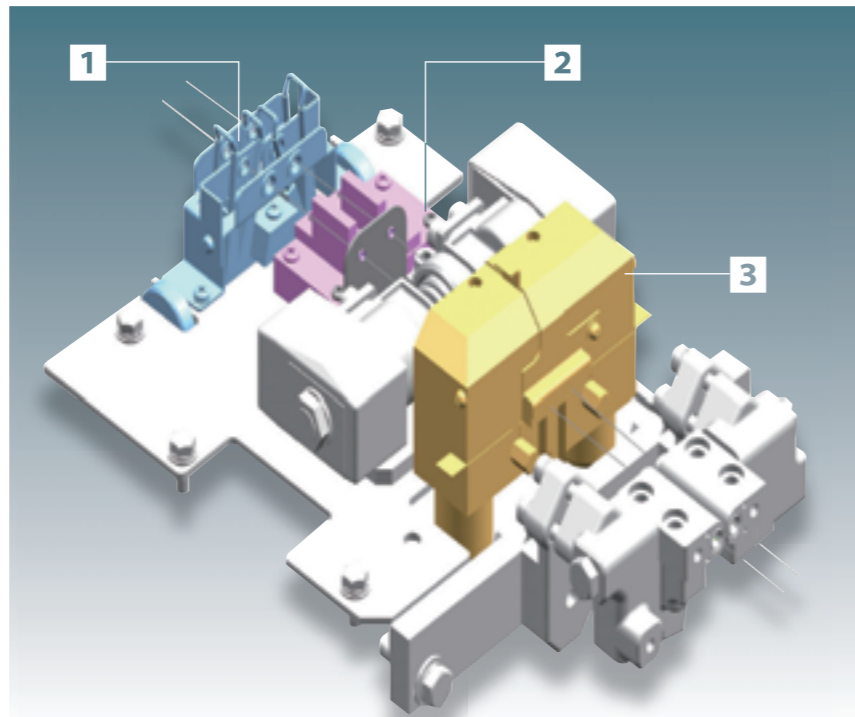

■ 1 ABS (OP)

This system reduces peak insertion tension on 2-nozzle pick-at-will and is very effective for weaving textures or stretch yarns.

■ 2 Weft Breakage Detector (OP)

Our original photoelectric sensor can detect weft breakage without the yarn being touch. This reduces the chances of yarns being damaged.

■ 3 Air Pull-Back Device (OP)

This device is very effective for weaving high twist yarns on 2-nozzle models. Air is used to pull back weft tails at the nozzles to stabilize yarn position to prevent entanglement which allows for higher weaving speeds to be reached.

*Please contact about assembly of device.

Water Jet Loom LWT810

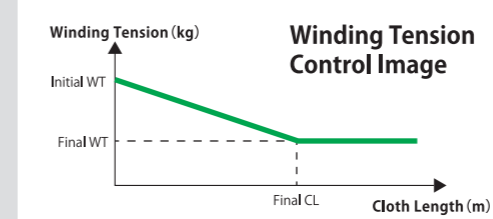
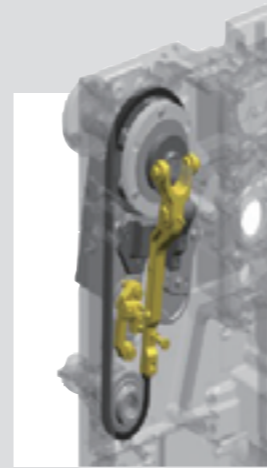

■ w-ITC (OP)

A wide range of winding tension is settable by motor control. It helps reduce wrinkles which improves the overall quality of cloth.

■ Double Pump (OP)

Adds the capability of setting pressure of each nozzle which allows for separate insertion timing control. This is effective for high-speed weft insertion.



■ IR Feeler

IR Feeler / Standard equipment infrared feeler offers improved reliability over wider range of yarns such as mono-filament, high-twisted yarn, fine and coarse count at high speeds.

■ Total Stop-Mark Prevention System

The powerful CPU controls many devices, including let-off and take-up mechanisms, effectively preventing stop marks.

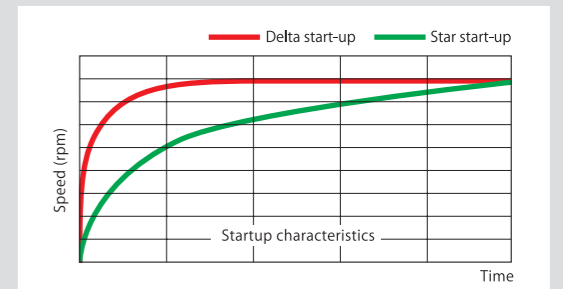
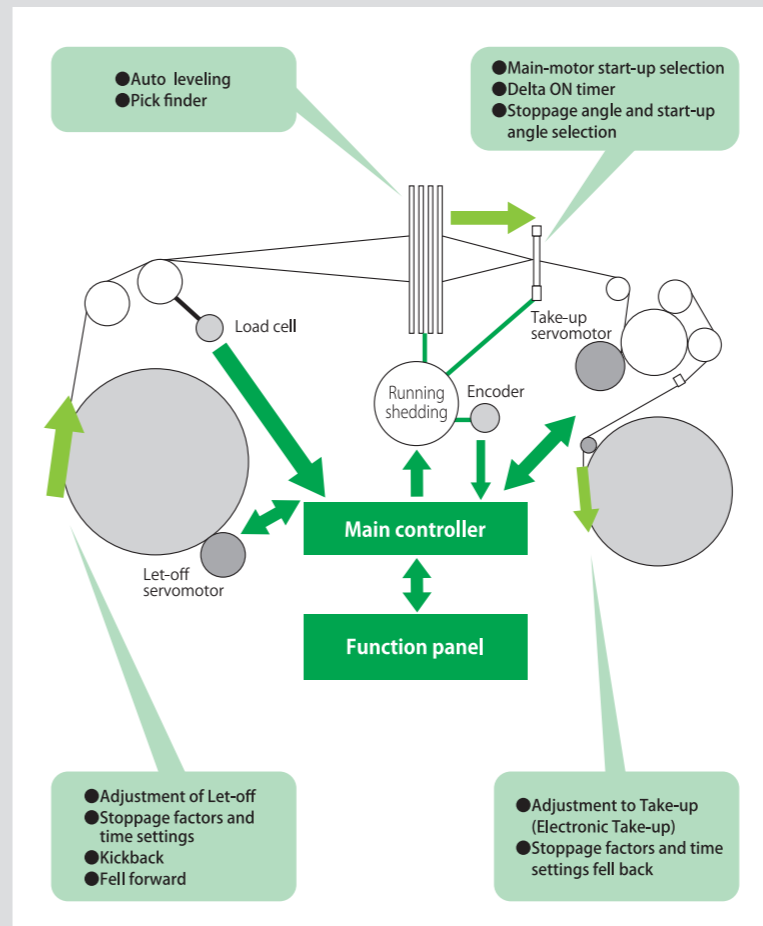

■ Selection of the Main-motor Start-up Method

The super-fast start-up motor ensures full beating power from the first pick. Either a delta or star configuration can be selected for motor start-up, offering different start-up torques to prevent heavy or light filling bar defects.

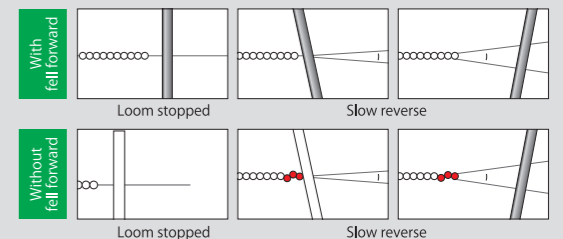

■ Fell Forward

Releasing warp yarn tension immediately after the loom stops prevents the cloth fell from touching the reed, thus eliminating a cause of stop marks. When the loom is restored, the beating resumes at the normal cloth fell position.

■ Let-Off Adjustment

The operator can set the amount of let-off permitted as needed in response to machine stoppages or downtime, thus reliably preventing stop marks.

■ Selection of the Machine Stoppage Angle and Start-up Angle

The stoppage angle and start-up angle can be selected to match the type of fabric and prevent stop marks.

Reliability – Realize High Level Quality.

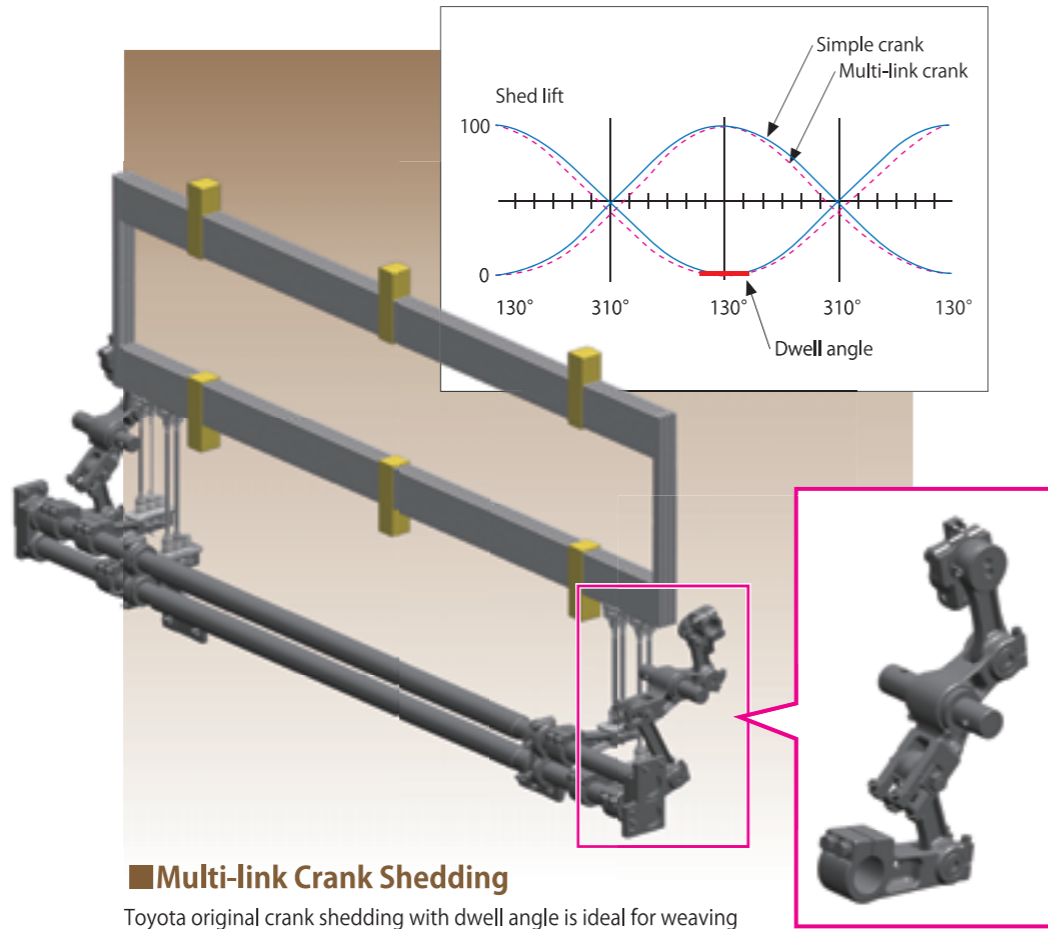

Multi-link Crank Shedding

Toyota original crank shedding with dwell angle is ideal for weaving densely woven fabrics.

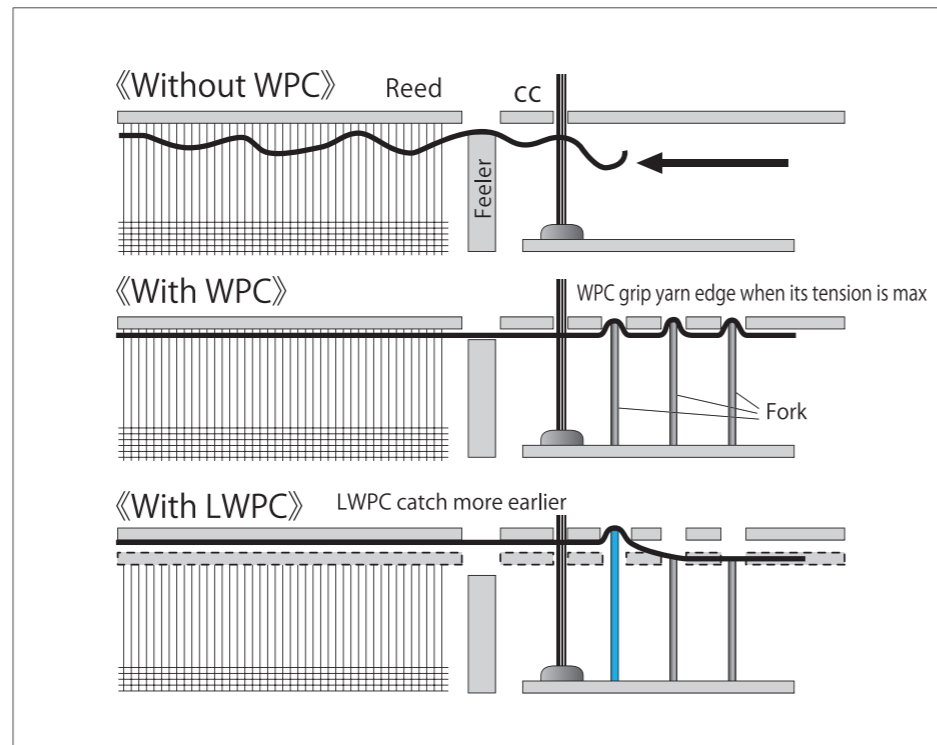

LWPC

LWPC grip yarn edge earlier makes a uniform weft yarn tension and improves fabric quality.

Water Jet Loom
LWT810

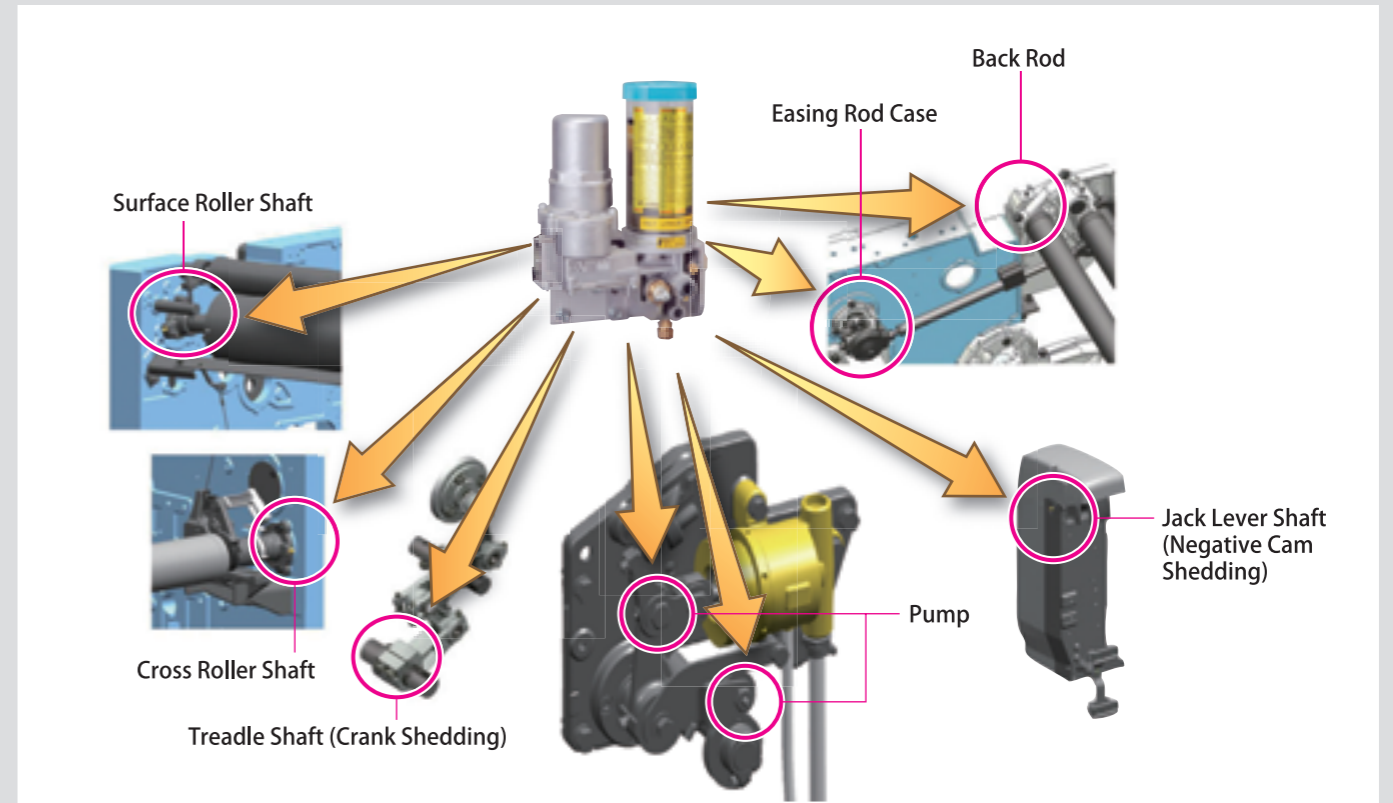

Fully Automated Centralized Lubrication **OP**

Lubricant is automatically supplied by designating lubrication times and intervals via the function panel.

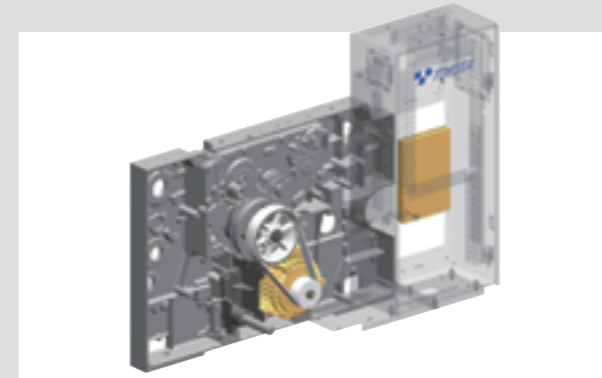

New SC inverter **OP**

The New SC Inverter has multiple new technology advancements including easy operation to control weaving speed by one touch. It also offers a reduction of space with the SCI now built in the control box.

Positive Easing **OP**

Positive easing is ideal for a wide range of materials, particularly heavy or densely woven fabrics. It also offers consistent synchronized movement during high-speed operation.

Automatic Weft Tail Removal **OP**

Removal of weft tails is automatically accomplished through simple design.



Pump for High-Speed Insertion and Wide Width Weaving **OP**



Factory Management



1
2
3

Toyota Factory Management System (FACT) ^{OP}

Toyota developed the new factory management system based on the Toyota Monitoring System (TMS). Data such as shift reports and stop analysis graphs currently available can be displayed, as well as various breakouts showing operating status with sequence according to actual factory layouts. FACT data can be viewed not only from an office computer, but also from a loom function panel or tablet.

1 Stop Analysis Graph

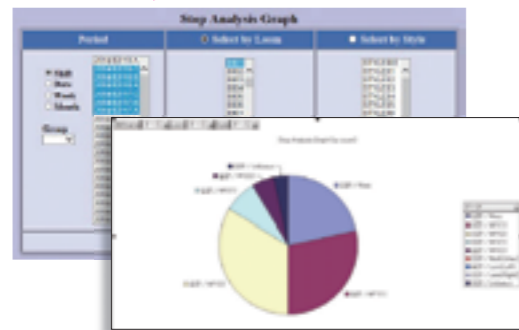

2 Cloth Roll Map



Uses a roll map to show stoppage location and the cause of the stop.

3 Operation Condition Screen



[Operation Monitor Mode]
Give easy-to-see operating conditions according to actual factory layout.



[Doffing Forecast Mode]
Predicts which looms will require cloth doffing within the next hour.



[Wrap Out Forecast Mode]
Predicts which looms will have wrap out within the next hour.

Internet-TTCS and TMS (Toyota Monitoring System) will continue to be available.

Shedding

Negative Cam Shedding, Crank Shedding, Positive Cam Shedding, Electronic Dobby Shedding

Negative Cam Shedding

Proprietary Toyota shedding technology provides for optimum cam curves.

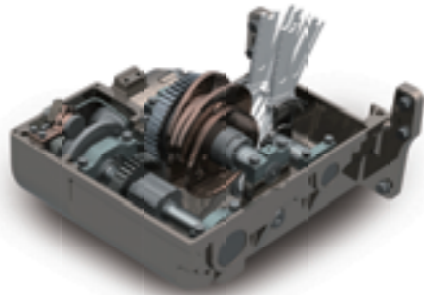

Electronic Dobby Shedding



Installation dimensions

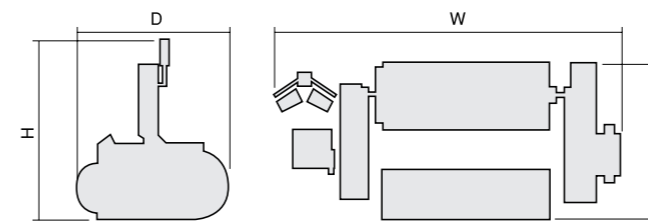

		Negative cam	Crank	Positive cam	Dobby
Machine width (W)	1C (BLD)	R/S+1799	R/S+1544	R/S+1544	R/S+1544
	2C	R/S+2029	R/S+1774	R/S+1774	R/S+1774
Depth (D)		1805	1805	1805	1805
Height (H)		1966	1966	2295	2332

(Note 1) The dimensions shown apply to the following specifications:
1. R/S 170 to 280
2. Yarn beam flange diameter: 800
3. Max. roll diameter: 520
(Note 2) Dimensions may differ depending on the required specification. Please contact us for final confirmation of size.



Main Specifications

Item	Standard specifications
Drive	Super-fast start-up motor Start, stop, forward / reverse slow motion Activated by push-button operation Solenoid-brake stoppage Automatic compensation for fixed-position stops
Beating	Two-sided crank drive with oil bath Multiple short sleysword
Let-off	Electronic Let-off Motion Negative-easing double back rollers
Take-up	Mechanical take-up motion Flat cloth line
Weft insertion	Flange-type pressurized pump Adjustable ring nozzle Auto pick finder
Temple	Lower cover temple
Stop mark prevention	Selectable main motor start-up Selectable stop / startup angle Adjustable let-off amount Fell forward
Selvage	Planetary-gear leno type (enclosed gears)
Waste Selvage	Waste selvage on the right with catch cord
Water extraction	Circulating-flow steam-separator type (moisture-removal tank) Energy-saving high-pressure blower
Cutter	Mechanical cutter
Stop motion	Leno selvage and waste selvage stop motion IR Feeler LED 4-color signal lamp
Lubrication	Oil-bath lubrication method for main parts, grease supply method
Main controls	Large 12-inch interactive touchscreen color function panel 32-bit CPU & function panel Fiber-optic and Ethernet LAN communications network
Function panel	24-hour / weekly efficiency graphs, beam and cloth prediction, standardized condition automatic set up (CS) Displays individual stop causes Weavers monitor New Weaving Assist System (WAS)

Item	Variations
Designated reed width (R/S)	170 cm, 190 cm, 210 cm, 230 cm, 280 cm
Beating	Super-short stroke ML beating
Beating	Positive-easing double back rollers (Front / rear adjustable position)
Yarn beam	Dia. 800 Dia. 914 Dia. 1,000
Temple	Full width temple
Shedding	Negative cam (max. capacity 10 frames) Crank (max. capacity 6 frames) Dobby (max. capacity 16 frames)
Weft insertion	Single pump Double pump
Length measurement	BLD measurement Roller feeder with speed control

Main Options

- Intelligent Take-Up Controller (ITC)
- w-ATC
- ABS
- Tensioner
- w-IFC
- Automatic bobbin change
- Balloon cover
- Electronic take-up motion with density variable method
- Slanted cloth line
- Weft Breakage Detector
- Air Pull-Back Device
- Independent catch cord shedding
- Fully Automated Centralized Lubrication
- Speed control inverter
- Pump for High-Speed Insertion and Wide Width Weaving
- Toyota Total Computer System (Internet TTCS)
- Toyota Monitoring System (TMS)
- Toyota Factory Management System (FACT)

1) For further details and information concerning other combinations of options and variations, please contact Toyota or your Toyota representative.
2) Drawings, data, and photograph which appear in this catalogue are subject to change without prior notice.

GLOBAL SERVICE NETWORK

Total Customer Support Based on Total Customer Service

Toyota offers a full range of services specifically tailored to individual customers — from design of the mill layout to installation and after-sales service. In addition, at the Toyota Textile Machinery Training Center, we offer a wide range of courses that match the needs of individual customers. Here, technical engineers from around the world get the latest know-how needed for smooth operation of all Toyota textile machinery.

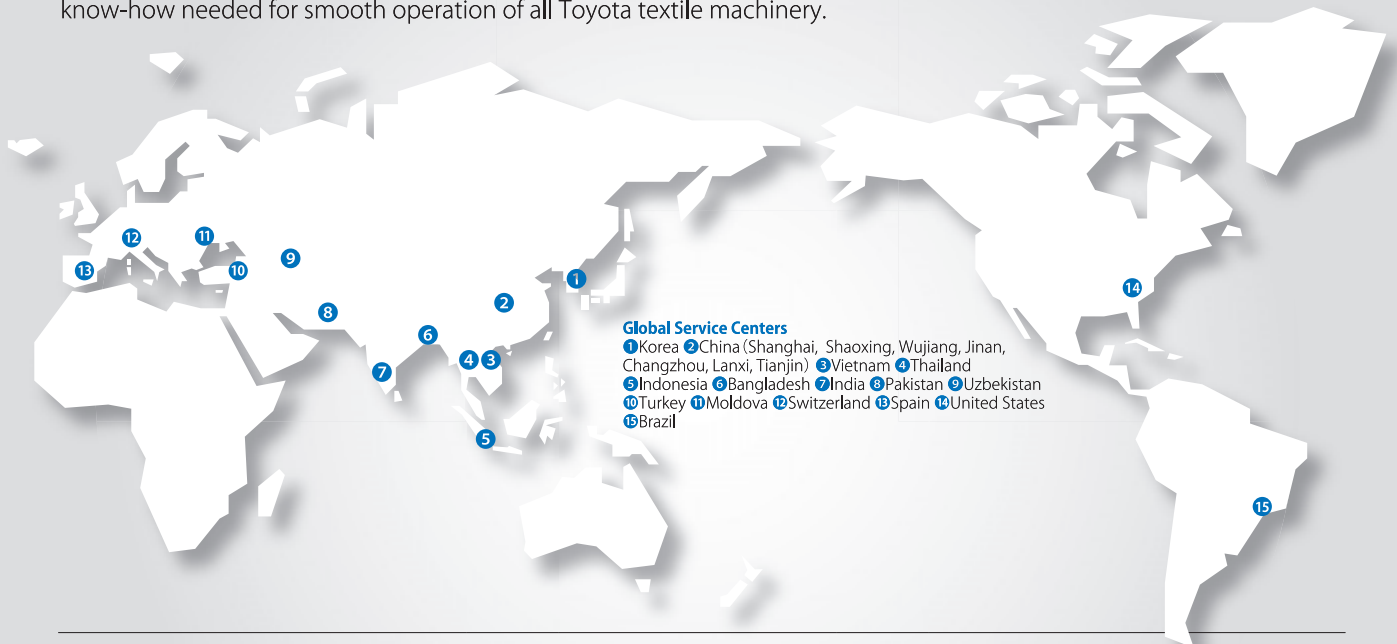

Global Service Centers

① Korea ② China (Shanghai, Shaoxing, Wujiang, Jinan, Changzhou, Lanxi, Tianjin) ③ Vietnam ④ Thailand
⑤ Indonesia ⑥ Bangladesh ⑦ India ⑧ Pakistan ⑨ Uzbekistan
⑩ Turkey ⑪ Moldova ⑫ Switzerland ⑬ Spain ⑭ United States
⑮ Brazil

1. Layout

Toyota proposes designs for layout and installation of looms in the mill, and offers plans for the machinery and equipment most suitable for customer mill requirements.

2. Installation

Toyota supervisors will visit the customer's mill and provide advice ranging from loom placement and installation to operational guidance.

3. After-Sales Service

After looms have been delivered, Toyota will actively provide after-sales service, including supplying the spare parts needed for smooth loom operation.

4. Training

In response to customer requests, Toyota has set up training courses ranging from how to use the machines to brushing up management skills. Toyota also helps train skilled experts adept in both the hardware aspects of its products.

5. Global Service Network

With a number of service centers located around the world, Toyota is able to quickly respond to the needs of local customers.

TICS

The Toyota Internet Customer Support system (TICS)* connects Toyota and its textile machinery users through the Internet to provide information such as parts inventory and price, enabling our customers to get information they need when they need it.



Part number search



Price estimate



Order status inquiry

*Data of TICS availability differs from region to region.



TOYOTA INDUSTRIES CORPORATION

Textile Machinery Division

2-1, Toyoda-cho, Kariya-shi, Aichi 448-8671, Japan

Sales Department

Tel: +81-566-27-5328 Fax: +81-566-27-5301

Service Department

Tel: +81-566-27-5325 Fax: +81-566-27-5681

<https://cybermill.toyota-industries.com/>