



Ring Spinning Frame

**RX300**

# Ring Spinning Frame RX300

## Taking Energy Efficiency and Flexibility to New Heights.

Toyota's RX Series of high-performance ring spinning frames—counting over 22 million spindles in operation around the world—now enters a new generation “RX300”. Toyota's RX Series will continue to evolve to always meet customer needs and offer the best solution.



### Remarkable Energy Savings

- Spindle and drafting drive use new motors that offer high efficiency and high energy-saving performance.
- The configuration of the pneumatic system has been improved, ensuring efficient suction with low drive power.

### All-In-One High Versatility

- From Cotton 100% to Synthetic Fiber, from coarse count to fine count, normal yarn, compact yarn, and fancy yarn can be covered by one machine.
- Just by attaching and detaching the unit of parts, Normal Yarn, Compact Yarn, and Mosaic Yarn can be switched.

### High Productivity and High Reliability

- Servomotor-driven screw shaft-type positive lifting that does not use belts has been adopted for ring-rail lifting.
- Robust Frame Structure ensures precise operation over long periods of long frame.
- Ideal balloon control is achieved through balloon control ring two-stage motion.

HIGH PRODUCTIVITY  
EASY MAINTENANCE  
HIGH QUALITY

**Example:**  
Power consumption of spinning frames in a typical spinning mill

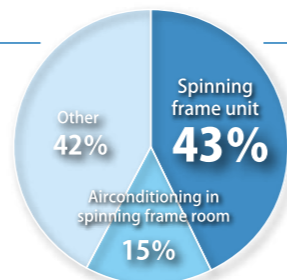

**High-performance, High-efficiency, Energy-saving Main Motor and in Inverter.**

In addition to the high-efficiency induction motors used in conventional models, the RX300 can be fitted with an optional super-energy-saving motor and a special inverter. These two options employ new technologies that enable energy-saving operation with even greater efficiency.

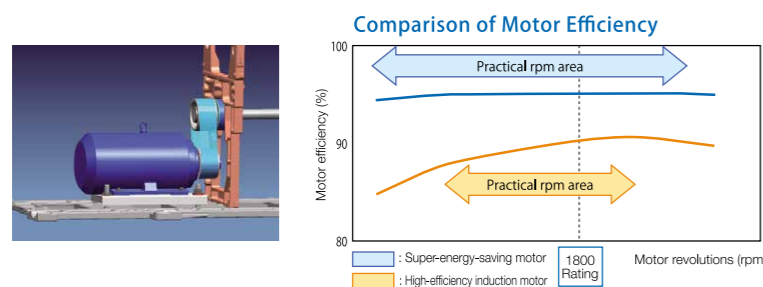

**The super-energy saving motor reduces power consumption by approximately 5%**

\*Actual power consumption varies depending on the mechanical conditions and the spinning conditions, etc.  
[Spinning conditions] Cotton100% / NE30  
[Mechanical conditions] 185 mm LIFT / 38 mm Ring / Spindle rpm 20,000 rpm

**Improved pneumatic system ensures stable yarn quality and energy-saving performance by keeping the suction pressure constantly optimised.**

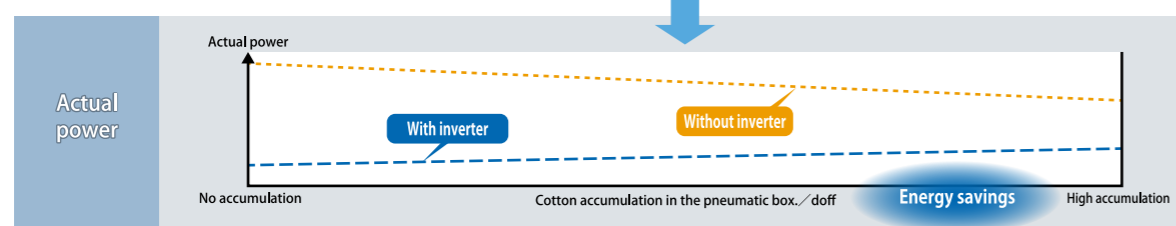
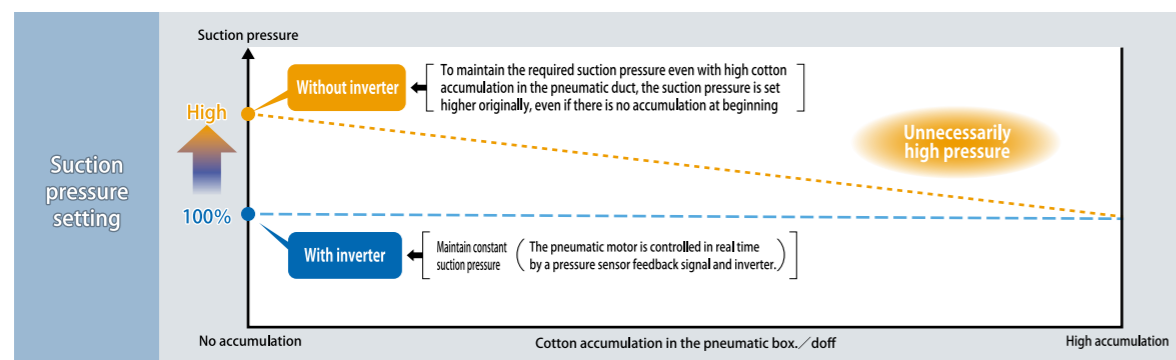
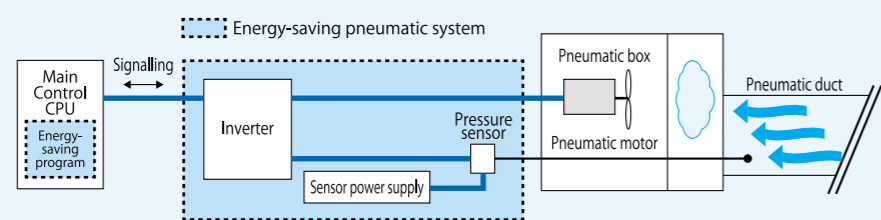

**World's First Ring Spinning Frame to Eliminate All Change Gears (RX300E)**

The RX300E e-draft model is the world's first ring spinning frame to eliminate all change gears for the drafting. The break draft and the main draft on RX300E are changed just by a simple touch on the function panel, together with the Twist, or the settings of the unique Toyota ring rail lifting system.



Spinning condition settings

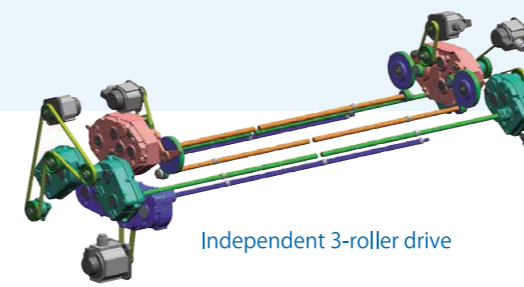

**Fancy Yarn Spinning Device**

Many types of fancy yarns can be handled such as slub, multi-count, and multi-twist ones. High-response servo motors drive all three bottom rollers. This makes it possible to not only slow down the front roller, but also speed up the back roller. In addition, the supplied software makes it easy to record and manage pattern simulation and settings data.



**Types of Yarn Handled** \* Cross-section ratio of normal yarn to fancy yarn

<p><b>Positive Slub Yarn (up to 500%*)</b></p> <p>1) Front roller deceleration control (with change to twist) 2) Back roller acceleration control (with no change to twist) 3) Combined control of 1 and 2 above (degree of twist change can be adjusted)</p>	<p><b>Multi-count Yarn</b></p> <p>1) Fixed number of twisted threads (2-6) 2) Fixed number of twists (1-70 twists per inch) 3) Any number of twists (1-70 twists per inch)</p>	<p><b>Multi-count + Multi-slub</b></p>
<p><b>Negative Slub Yarn (up to 30%*)</b></p> <p>Back roller acceleration control</p>	<p><b>Multi-twist Yarn</b></p> <p>Number of twisted threads: 1.5-10</p>	<p><b>Slub on Slub</b></p>
		<p><b>Natural Slub Like</b></p>

**Settings Data Creator for Fancy Yarns (special software)**

- Pattern settings:** 1,000 x 1,000-line
- Available patterns:** Single, Multiple, Stepped, Random
- Simulation:** Part of the pattern data can be corrected
- Data transfer:** USB Memory, ethernet communication

<p><b>Common Settings Screen</b> Select pattern implementation mode or roller control mode</p>	<p><b>Pattern Table Screen</b> Automatically generate patterns</p>	<p><b>Slub Simulation Screen</b></p>
--	--	--------------------------------------

Toyota Original Compact Yarn Spinning System

**EST3**

Original suction type compact with high performance and yarn quality

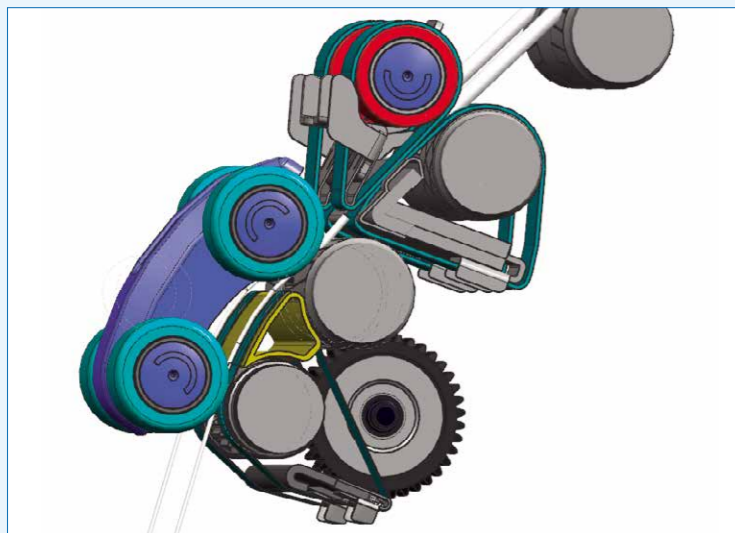

**Four-line Drive System with "Delivery Bottom Roller"**

- Actively drives the mesh apron. Slip-free rotation increases service life of the mesh apron.
- Easy to maintain regardless of top roller diameter.

**Long Mesh Apron With Spring-type Tension Device**

- Prevents accumulation of fly, and thus allows longer intervals between periodic maintenance.

**Integrated Suction System**

- The integrated suction system throughout the entire frame suppresses fly dispersion and ensures high productivity and yarn quality.
- Reducers on each block ensure uniform suction pressure across all blocks.

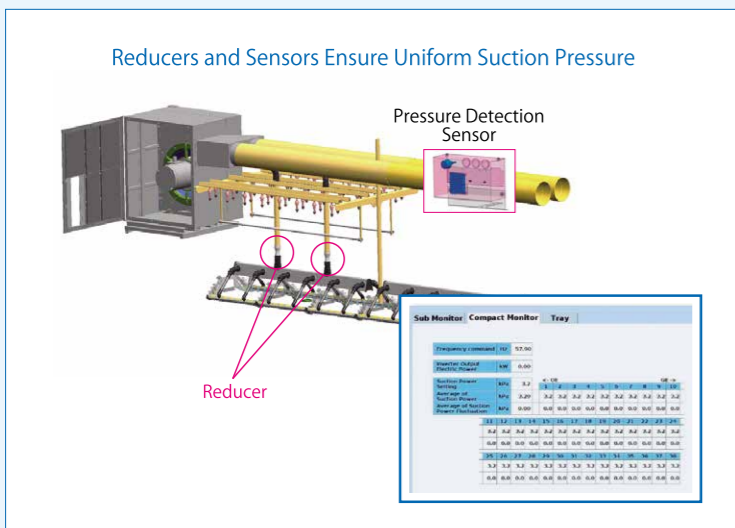
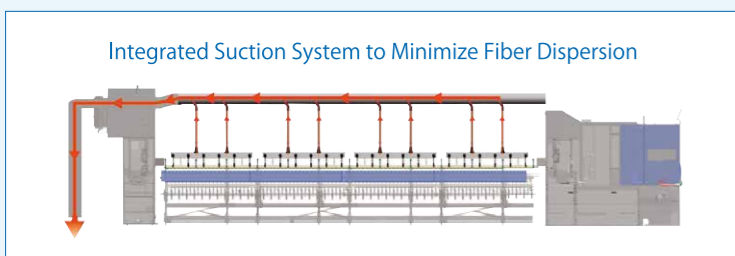

**Free Adjustment of Suction Pressure**

- The optimum suction pressure can be set according to the yarn count and desired yarn quality.

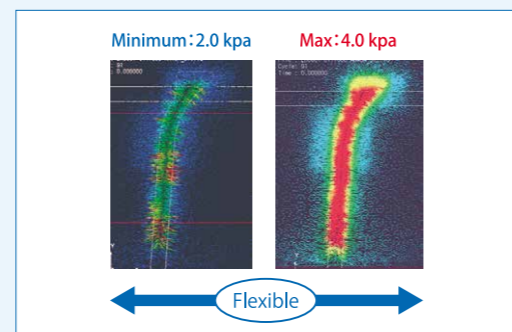

**Condensation Unit**

- Easy to remove and disassemble.
- Having a spare unit reduces machine downtime for cleaning.
- Can quickly switch between conventional yarn and compact yarn.

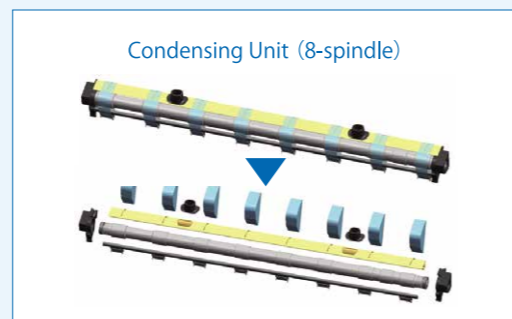

**EST4**

New model with enhanced versatility in addition to the functions of the EST3

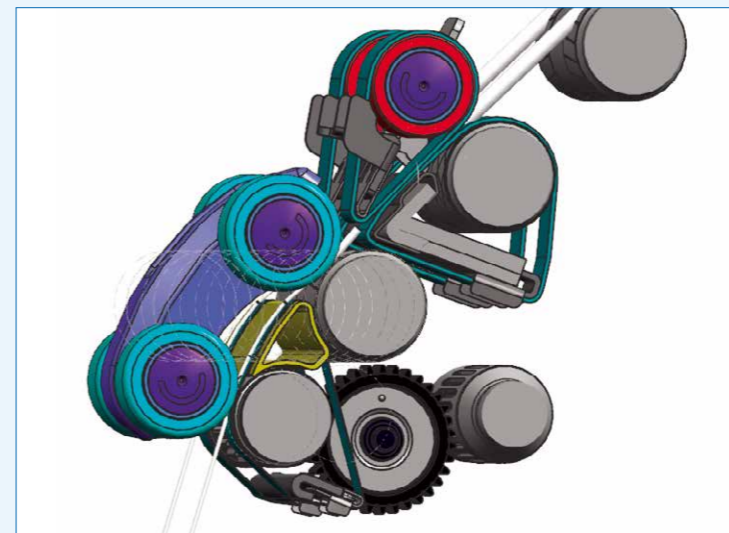

**For Various Materials and Applications [EST4]**

- The servo motor controls the delivery bottom roller to 4-line completely independent drive. The draft ratio in the compact zone can be freely adjusted, allowing compatibility with various fibers and yarn qualities.

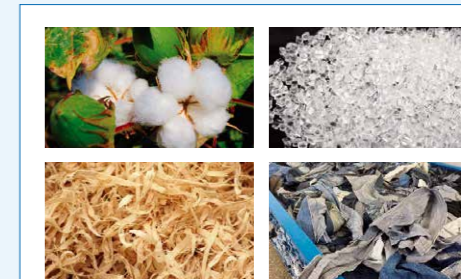

**Easy-to-Maintain Countershaft Mechanism**

- The drive system using a countershaft and carrier gear allows safe and easy attachment and detachment of the condensation unit.

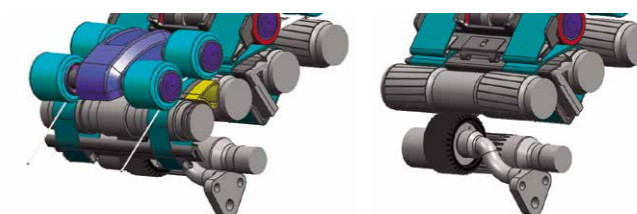

**Function and Features**

Item	EST3	EST4
Kind	Suction Type Compact	
Bottom Roller	4-line Type	
Condensing Unit	Detachable Condensing Unit	
Compact Apron	Mesh Apron Type	
Applicable Yarn Count	Coarse to Fine	
Fancy Yarn	Available	
Drive System	Front Roller Carrier Gear Drive	Servo Motor Drive (Countershaft, Carrier gear)
Tension Draft Setting	Fixed	Adjustable (0.940 ~ 1.070)
Applicable Fibers	100% Cotton	100% Cotton ~ Recycled Fiber, Synthetic Fiber

**Toyota Original Innovative Yarn MOSAIC® (Mosaic)**

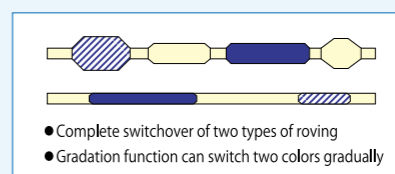
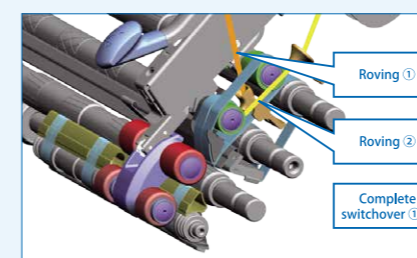

## High Reliable and Performance Even for Long Frame

### 1 Robust Frame Structure

Spring pieces made of cast iron (3 pieces used for each block [48 spindles]) Integrated right-left roller stand made from die-cast aluminum

- Stable long-term operation with extra spring piece
- Easy centering of the bottom roller

Various types of yarn such as compact yarn, fancy yarn, and siro yarn can be spun on this long-frame machine that can accommodate up to 1,824 spindles.

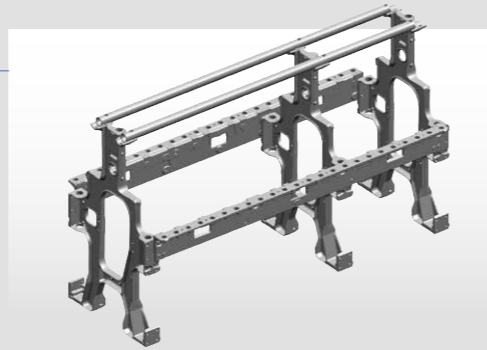

### 2 Bottom Roller Split Drive

The bottom roller drive in the MH to OE sections uses the same configuration as that used in two-head machines. Adding another set of motors to the GE side enables on-board changes without any change gears, even on a 1,824-spindle machine. Each roller is driven by a servomotor to ensure precise synchronization.

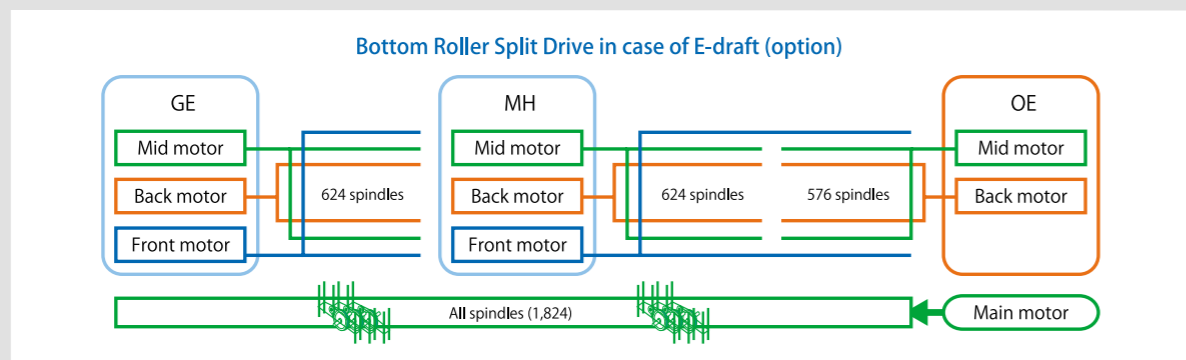

## Stepless, Independent Motion of the Balloon Control Ring

The RX300 uses a balloon control ring that moves together with the lappet at the start of winding and then with the ring from about 40% cop winding. Because the balloon control ring is always working effectively, balloon form is stable and there's less yarn breakage.

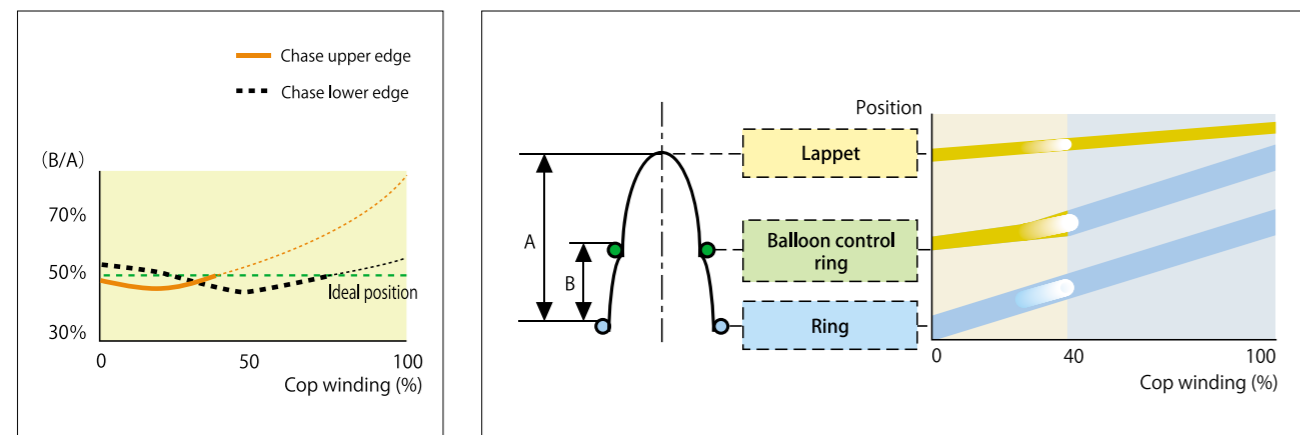

## Toyota original Servo Motor-Driven Positive Lifting

Instead of belts, the RX300 incorporates a screw shaft positive lifting mechanism. This eliminates disparity in the ring rail motion during long periods of continuous operation. The RX300's smooth lifting motion also eliminates many of the problems associated with conventional lifting systems. Disruptions, such as stoppages that often occur during ring rail inversion and annoyances like chattering during descent, become things of the past.

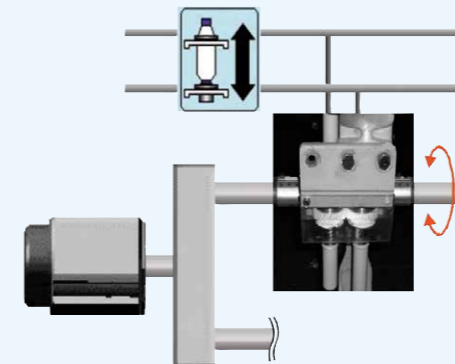

### Ring Rail Inversion Comparison

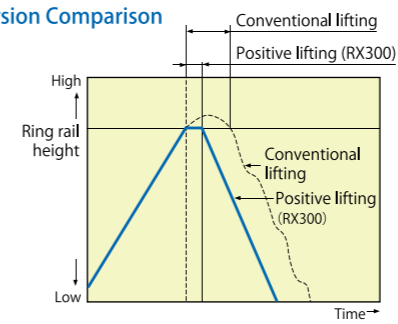

### The Perfect Solution for Fly Accumulation

The screw shafts are covered, and their pillars are completely sealed to prevent fly accumulation.



### Adjustable Lifting Motion Reduces Yarn Breakage when Restarting

The RX300 reduces the occurrence of yarn breakage by allowing free setting of the lifting rate.

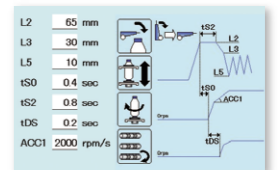

Automatic ring rail lifting

### Optimal Cop Formation at Your Fingertips

With easy key operation, it becomes very simple to find an optimal setting for cop formation to match various spinning conditions.

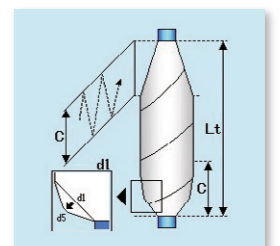

## High-Speed Auto Doffer

Full and empty bobbins can now be handled at high speed accompanying the increase in the number of spindles. It has become possible to transfer 40 bobbins per minute, and coarse yarn counts can also be handled.



Middle-peg system accommodates large-diameter cop packages

## Bobbin Feeder

We have newly added a basket-type bobbin feeder to our product lineup, contributing to factory automation.



# Provides Outstanding Control and Operability

## High-Performance CPU Control

High-precision control is achieved through a 32-bit CPU combined with our latest inverter and servo amplifier. A high level of dependability is assured for both spindle speed and servo-lifting control.

## Large Color Function Panel

A 12-inch color function panel equipped with a Web browser improves interface ability. Connection to an internal or external network is possible for exchange of information or data.

### Function Panel

#### Setting functions

- Spinning conditions ● Cop formation (one-touch setting for the number of bunch windings and back windings)
- Spindle speed control (easy pattern setting function, speed control pattern graph display) ● Ring plate movement
- Doffing conditions

#### Monitoring functions

- Production volume (shift counter) ● Transition of efficiency for each shift
- History of running conditions for the last 24 hours ● Spindle speed, delivery speed, twists, and time to full bobbin
- Inverter/servo amplifier monitor ● Troubleshooting

#### Management functions

- Setting condition memory function ● USB flash drive ● Maintenance schedule management function

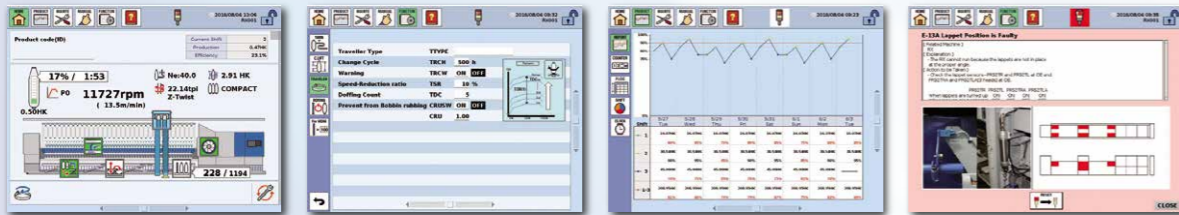

Top menu

Settings for traveler pre-conditioning operating mode

Efficiency transition graph

Troubleshooting

## TMS (Toyota Monitoring System)

By using Toyota's original monitoring software, the operator can easily obtain various information such as shift reports, simply by connecting multiple frames.

The operator can view the RX300's function panel directly from the office PC and check various machine conditions such as spinning settings.

Data can be exchanged between spinning frames without using memory cards.

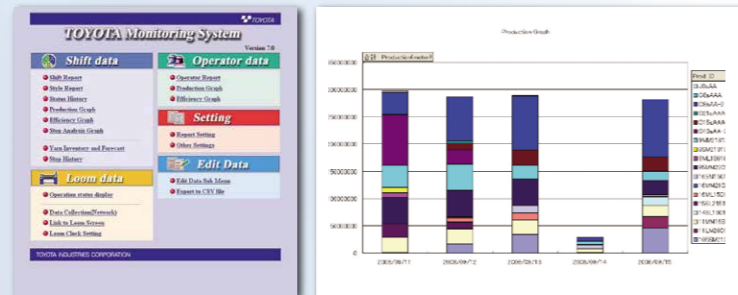

Top menu

Production volume

### Main Specifications

- Spindle gauge: 70 mm / 75 mm
- Bobbin length (lift): 180 (155) mm / 210 (185) mm / 230 (205) mm
- Spindle driving system: 4 spindles by spindle belt
- Fiber length: Max. 51 mm
- Yarn count to be spun: Ne1-300 (settings)
- Max. number of spindles: 1,824
- Ring diameter: 36-53 mm
- Drafting system: 3-line 2-zone
- Lifting motion: Screw shaft-type positive lifting
- Dimension of roving bobbin: 146 x 406 mm
- Function panel: Large color graphic panel
- Spindle speed control: Arbitrary speed control inverter
- Automatic doffer: SCD (automatic stationary cop doffer) with automatic restarting mechanism, winder link, or automatic bobbin changer

### Main Options

- Fancy Yarn Spinning Device  
Front roller deceleration and back roller acceleration  
Slub thickness 30% to 500%  
Comes with special software
- Compact Yarn Spinning Device  
Mesh apron suction method  
Mesh apron positive drive

Design and specifications are current as of August 2023.

## RX300E Dimensions

MH: Middle head/ PN2: Second pneumatic box

\*Machine heights increase by 70 mm when fitted with a compact yarn spinning device (EST III) or TBC (Toyota automatic bobbin changer) for 250 mm (9-inch) bobbin.

### Linked Winder Specification

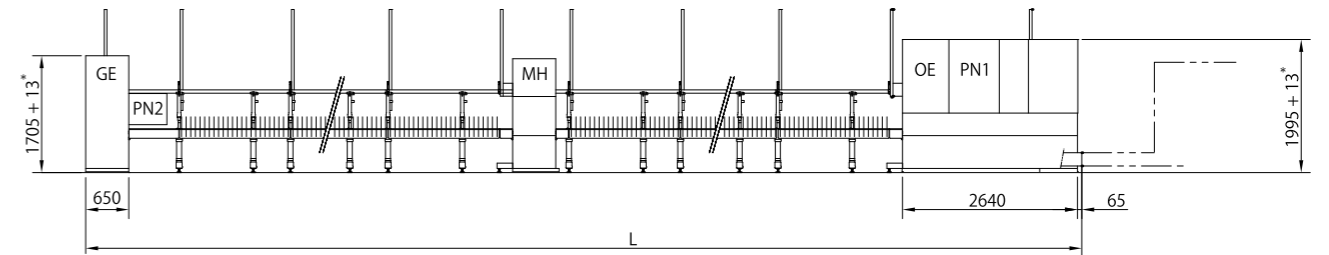

### Bobbin Feeder Specification

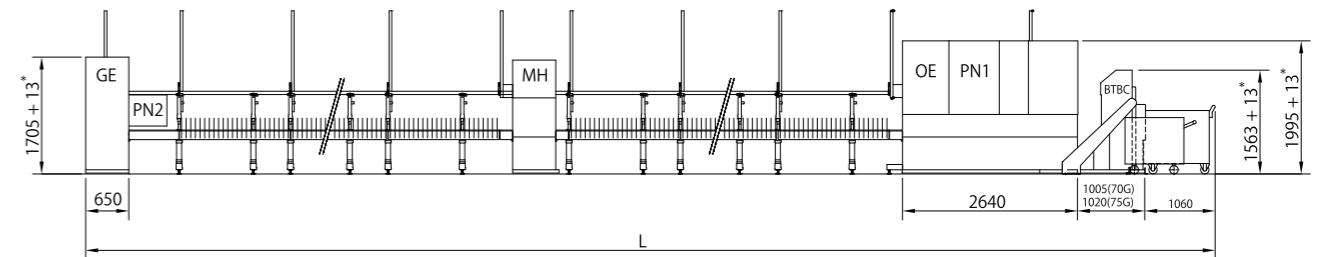

## Frame Length by the Number of Spindles

No. of spindles	L (Unit: mm)				MH-PN2
	Bobbin Feeder Specification		Linked Winder Specification		
	70 mmG	75 mmG	70 mmG	75 mmG	
1,008	41,035	43,570	39,035	41,555	Without
1,056	42,715	45,370	40,715	43,355	
1,200	47,755	50,770	45,755	48,755	
1,440	56,155	59,770	54,155	57,755	With
1,632	64,525	68,620	62,525	66,605	
1,728	67,885	72,220	65,885	70,205	
1,824	71,245	75,820	69,245	73,805	

## Required Dimensions for Auto Doffer

- (A) Max. width of auto doffer (when doffing): 1,540
- (B) Min. length between center lines of 2 adjacent frames: 2,100 - 2,300
- (C) Min. length between center line of frame and pillar: 1,500

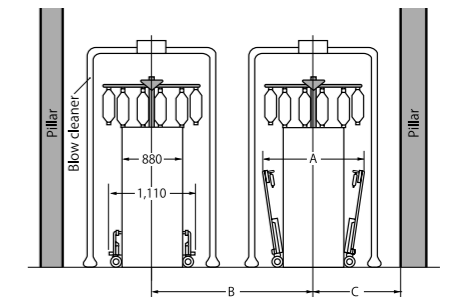

## USTER® SENTINEL Ring Monitoring System

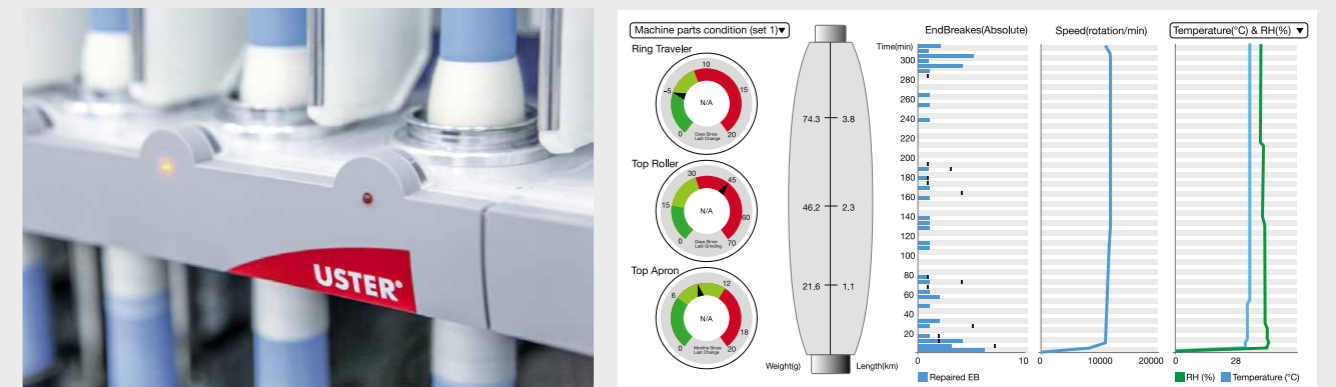

End-break Sensor

Bobbin Build-up Report

The USTER® SENTINEL ring monitoring system, designed by our group company USTER, detects end-breaks and uses LEDs to notify the operator, thereby improving productivity. Multifunctional management software enables real-time monitoring of various parameters, and early detection of problems contributes to optimized quality and cost.

# GLOBAL SERVICE NETWORK

## Total Customer Support Based on Total Customer Service

Toyota offers a full range of services specifically tailored to individual customers – from design of the mill layout to installation and after-sales service. In addition, at the Toyota Textile Machinery Training Center, we offer a wide range of courses that match the needs of individual customers. Here, technical engineers from around the world get the latest know-how needed for smooth operation of all Toyota textile machinery.

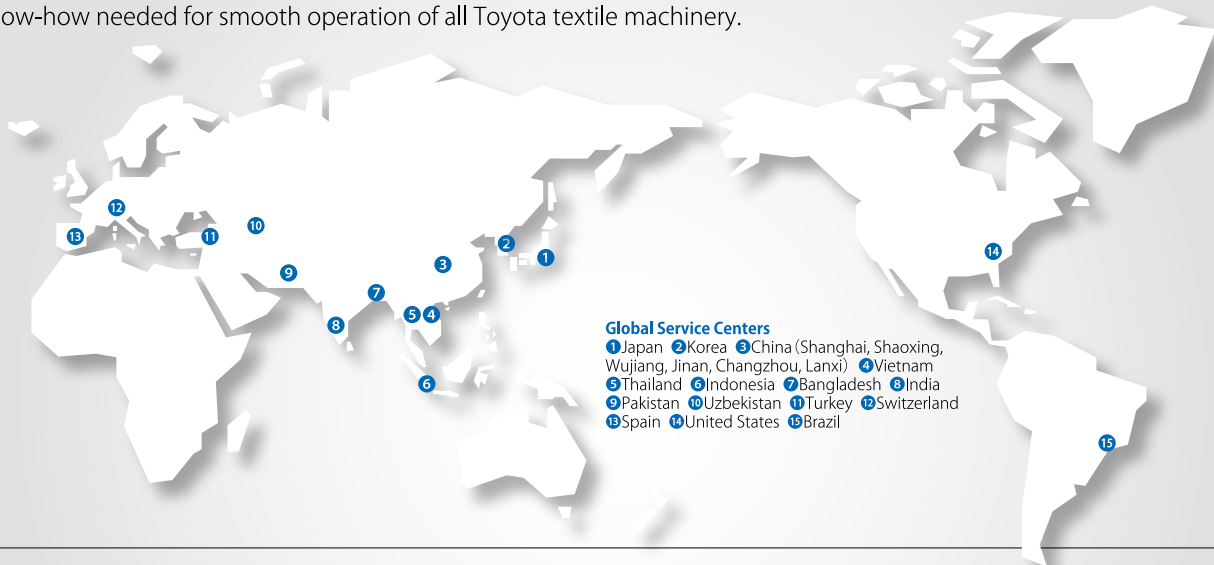

### Global Service Centers

1 Japan 2 Korea 3 China (Shanghai, Shaoxing, Wujiang, Jinan, Changzhou, Lanxi) 4 Vietnam  
5 Thailand 6 Indonesia 7 Bangladesh 8 India  
9 Pakistan 10 Uzbekistan 11 Turkey 12 Switzerland  
13 Spain 14 United States 15 Brazil

### 1. Layout

Toyota proposes designs for layout and installation of spinning machines in the mill, and offers plans for the machinery and equipment most suitable for customer mill requirements.

### 2. Installation

Toyota supervisors will visit the customer's mill and provide advice ranging from spinning machine placement and installation to operational guidance.

### 3. After-Sales Service

After spinning machines have been delivered, Toyota will actively provide after-sales service, including supplying the spare parts needed for smooth spinning machine operation.

### 4. Training

In response to customer requests, Toyota has set up training courses ranging from how to use the machines to brushing up management skills. Toyota also helps train skilled experts adept in both the hardware aspects of its products.

### 5. Global Service Network

With a number of service centers located around the world, Toyota is able to quickly respond to the needs of local customers.

## TICS

The Toyota Internet Customer Support system (TICS)\* connects Toyota and its textile machinery users through the Internet to provide information such as parts inventory and price, enabling our customers to get information they need when they need it.

\*Data of TICS availability differs from region to region.

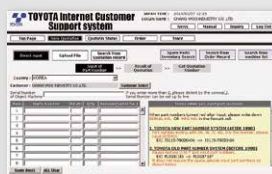

Part number search

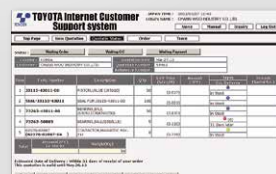

Price estimate

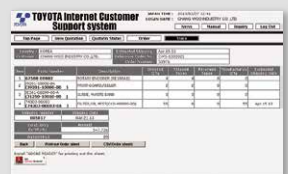

Order status inquiry



TOYOTA INDUSTRIES CORPORATION

### Textile Machinery Division

2-1, Toyoda-cho, Kariya-shi, Aichi 448-8671, Japan

### Sales Department

Tel: +81-566-27-5328 Fax: +81-566-27-5301

### Service Department

Tel: +81-566-27-5325 Fax: +81-566-27-5681



KIRLOSKAR TOYOTA TEXTILE MACHINERY PVT. LTD.

Factory: Plot No. 10-13, Phase II Jigani Industrial Area, Jigani, Bangalore 560 105, India

Tel: 91-8110-419555 Fax: 91-8110-419519 E-mail: mktg@kttml.com

### Coimbatore Branch

124-D, Crescent Court, Race Course Road, Coimbatore 641 018  
Tel: 91-422-2223183 Fax: 91-422-2220987 E-mail: kttmcb@kttml.com

### Delhi Branch

905-907, Kirti Shikhar, 11 District Center, Janakpuri, New Delhi 110 058  
Tel: 91-11-25537620/25513302 Fax: 91-11-25513304 E-mail: kttmdel@kttml.com

### Mumbai Branch

402, Dev-Milan Co-op Premises Society, Above Hotel Woodland Retreat, L.B.S. Road, Near Tip Top Plaza, Teen Hath Naka, Thane (West) 400 604  
Tel: 91-22-6798-8863/64 Fax: 91-22-6798-8865 E-mail: kttmbom@kttml.com

<https://textile-machinery.toyota-industries.com/>